



# SMD10-3A

## SYNC MODULE



- Polarized with wide operating voltage range using filtered DC or unfiltered FWR input voltage
- Mounts to 4" square back box
- Daisy chain up to 20 modules maximum
- Screw terminal capacity up to AWG #12
- Red metal plate



ME A



P/N: 18710

The Sync Module is designed to provide a synchronized temporal pattern (code 3) tone, and synchronize the strobe flashes when used with the Janus Fire Systems<sup>®</sup> Select-A-Strobe, Select-A-Horn, and Select-A-Horn/Strobe series as well as the ability to silence the horn while maintaining the strobe flashes.

The SMD10-3A has the capability of connecting two Style Y (Class B) circuits or one Style Z (Class A) circuit and is rated for 3 Amperes per circuit.

The SMD10-3A can be interconnected so that more than two alarm zones can be synchronized by connecting the sync terminals (daisy chain connection). The maximum number of interconnected modules is twenty. All inputs are polarized for compatibility with standard reverse polarity supervision of circuit wiring by F.A.C.P.

### Specifications

#### Input Voltage:

Regulated 24 VDC / VFWR

#### Operating Voltage Range:

16 - 33 VDC / VFWR

#### Max. Load on Loop:

3 Amp Average  
Max. 5 Amp Peak

#### Max. RMS Operating Current:

DC - 34 mA  
FWR - 68 mA

#### Mounting Back Box:

4" x 4" x 1 1/2"  
(101.6 mm x 101.6 mm x 38.1 mm)

#### Operating Temperature Range:

32°F - 120°F  
(0°C - 49°C)

### Compatible Janus Fire Systems<sup>®</sup> Products

Model	Series	P/N
H-1224R	Select-A-Horn	18645
SL-1224R	Select-A-Strobe	18646
SL-1224WP-R	Select-A-Strobe (Weatherproof)	99985
SH-1224R	Select-A-Horn/Strobe Combination	18647
SH-1224WP-R	Select-A-Horn/Strobe Combination (Weatherproof)	99986



## Daisy Chain Modules

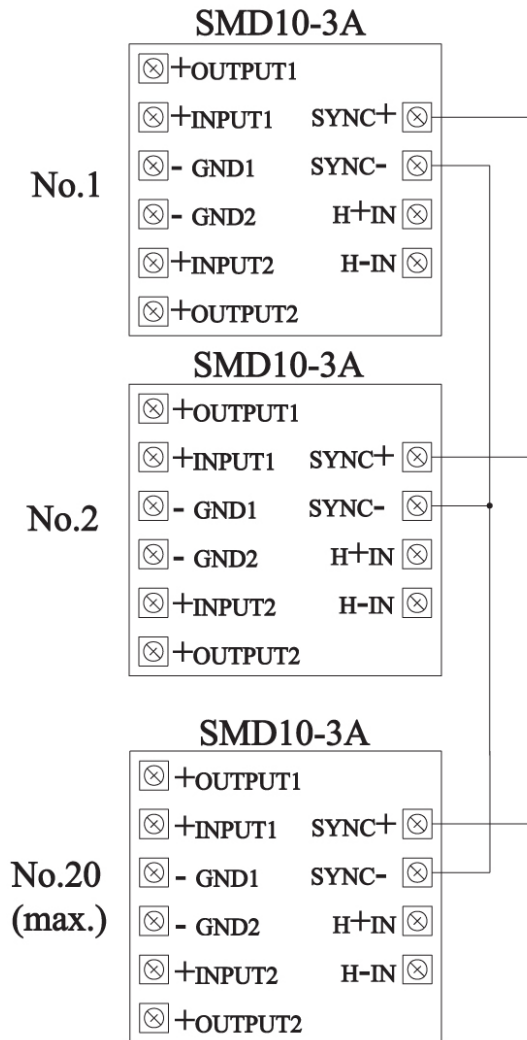

*Note: Approvals/Listings maintained by and manufactured by Potter Electric Signal Company.*

The seller makes no warranties, express or implied, including, but not limited to, the implied warranties of merchantability and fitness for a particular purpose, except as expressly stated in the seller's sales contract or sales acknowledgment form. Every attempt is made to keep our product information up-to-date and accurate. All specific applications cannot be covered, nor can all requirements be anticipated. All specifications are subject to change without notice.



1102 Rucpich Drive  
 Millennium Park  
 Crown Point, IN 46307  
 TEL: (219) 663-1600 FAX: (219) 663-4562  
 e-mail: info@janusfiresystems.com  
 www.janusfiresystems.com