



H-1224 SERIES

SELECT-A-HORN



P/N: 18645

- 33 sound output settings
- Horn or chime sound output
- Indoor/outdoor* listed
- Pre-wire back plate
- Universal back plate mounting (single gang, double gang, octagon, or 4" square)
- Single screw mounting
- Low current draw

Patents Pending

* Outdoor installation requires the BBK-1 (P/N 18865) or BBX-5 (P/N 99984)

The H-1224 Electronic Horn allows a number of applications on a single device. The horn settings include Temporal, Non-Temporal, March Time and a Chime sound. The horn also has Low, Mid and High volume settings for each pattern and tone. The tones include 2400 Hz, Electro-Mechanical, Broadband and Chime.

The voltage input can be either regulated DC or full wave rectified (FWR) 12 volt or 24 volt operation.

The H-1224 utilizes a universal mounting plate that will mount on a single gang, double gang, octagon and 4" square electrical boxes. Outdoor installations must use either the BBK-1 4" square (weatherproof bell backbox) or the BBX-5 (weatherproof backbox). The back plate allows the installer to mount the plate and terminate the wire connections. The horn attaches in a hinge fashion from the top and is secured by a single mounting screw. The horn completely covers the mounting back plate, therefore it can be mounted before other trades work is completed and not affect the final look.

Installation

SELECT-A-HORN
H-1224W

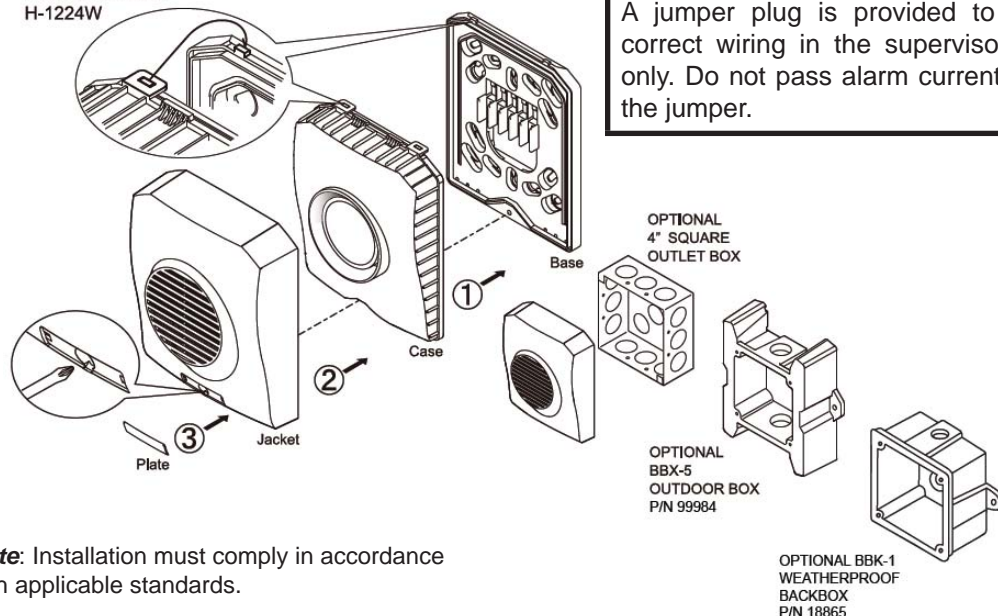

CAUTION

A jumper plug is provided to test for correct wiring in the supervisory mode only. Do not pass alarm current through the jumper.

Note: Installation must comply in accordance with applicable standards.



Non-Temporal Horn Current							
Pattern	Volume	Max. RMS Current (mA RMS Current)		dBA Reverberant Ratings per UL464 (dBA @ 10 ft.)		dBA Anechoic Ratings per CAN/ULC S525 (dBA @ 10 ft.)	
		Reg 12 VDC	Reg 24 VDC	Reg 12 VDC	Reg 24 VDC	Reg 12 VDC	Reg 24 VDC
2400 Hz	High	119	87	87	87	99	100
	Mid	44	28	82	82	94	96
	Low	30	18	79	80	92	92
Electro-Mechanical	High	118	81	86	87	100	100
	Mid	43	26	82	84	96	97
	Low	27	16	79	80	93	93
Broadband	High	146	78	86	86	101	102
	Mid	41	26	81	82	96	98
	Low	28	16	77	79	94	95
Chime	High	27	21	70	70	86	86
	Mid	11	8	62	62	79	80
	Low	9	7	58	57	75	75

Temporal Horn Current							
Pattern	Volume	Max. RMS Current (mA RMS Current)		dBA Reverberant Ratings per UL464 (dBA @ 10 ft.)		dBA Anechoic Ratings per CAN/ULC S525 (dBA @ 10 ft.)	
		Reg 12 VDC	Reg 24 VDC	Reg 12 VDC	Reg 24 VDC	Reg 12 VDC	Reg 24 VDC
2400 Hz	High	124	87	82	82	100	100
	Mid	46	30	77	79	95	96
	Low	30	18	74	75	92	92
Electro-Mechanical	High	114	80	83	82	100	101
	Mid	42	27	78	80	95	96
	Low	28	16	75	76	93	93
Broadband	High	151	80	82	82	101	102
	Mid	45	26	77	78	97	98
	Low	30	16	75	76	94	95
Chime	High	29	21	68	70	86	86
	Mid	10	9	61	61	79	79
	Low	9	8	55	55	75	76

March Time Horn Current							
Pattern	Volume	Max. RMS Current (mA RMS Current)		dBA Reverberant Ratings per UL464 (dBA @ 10 ft.)		dBA Anechoic Ratings per CAN/ULC S525 (dBA @ 10 ft.)	
		Reg 12 VDC	Reg 24 VDC	Reg 12 VDC	Reg 24 VDC	Reg 12 VDC	Reg 24 VDC
2400 Hz	High	121	92	83	84	99	100
	Mid	47	31	79	81	95	96
	Low	36	19	76	77	92	92
Electro-Mechanical	High	114	86	83	83	100	100
	Mid	42	27	80	81	95	96
	Low	30	19	77	77	92	93
Broadband	High	153	77	83	84	101	102
	Mid	42	28	79	80	97	98
	Low	29	16	76	77	94	95



Wiring Diagram

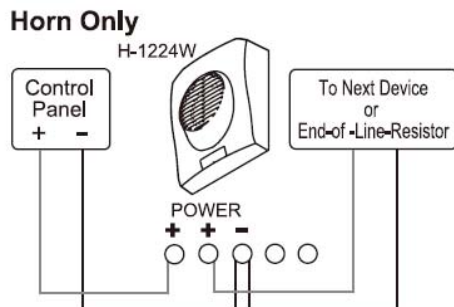

Wiring Observe Polarity Use both terminals (or Lead) for connection. Break wire run to provide electrical supervision.

Dimensions

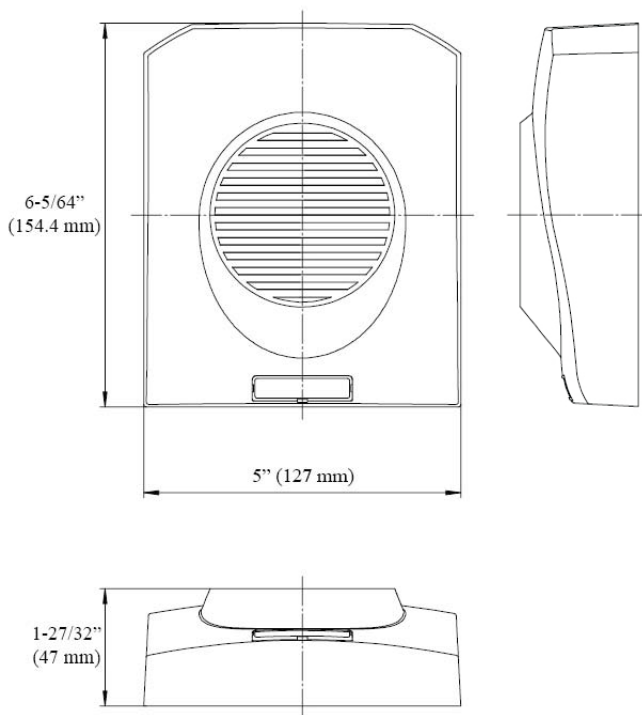

Dipswitch Settings

Pattern

- 1 ON - Non-temporal
- 1 OFF - Temporal
- Both 2 = OFF
- 1 and 2 ON = March Time

Tone

- 3 and 4 ON = 2400Hz
- 3 ON and 4 OFF = Electromechanical
- 3 and 4 OFF = Chime
- 3 OFF and 4 ON = Broadband

Volume

- 5 and 6 ON = High
- 5 ON and 6 OFF = Mid
- 5 and 6 OFF = Low
- 7 and 8 ON = N/A
- 7 and 8 OFF = N/A

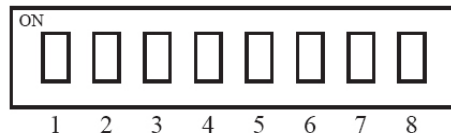

Specifications	
Voltage	12/24V
UL Designation	Regulated 12 DC/FWR Regulated 24 DC/FWR
Operating Voltage Range	8 - 17.5V 16 - 33V
Color	Red
Operating Temperature Range	Indoor: 32°F to 120°F (0°C to 49°C) Outdoor: -40°F to 151°F (-40°C to 66°C)



Engineering Specifications

The installer shall provide and install the H-1224 indoor/outdoor select-a-horn. The horn shall have thirty-three (33) different settings. The horn shall be selectable for continuous (non-temporal), temporal (ANSI Code 3) and March Time patterns. The horns shall have a 2400 hertz, Electro-Mechanical, Broadband or a Chime tone. Each of the patterns and tones shall be selectable for a Low, Mid or High volume setting. The horn shall operate at 12 or 24 VDC regulated or full wave rectified. The horn shall have an operating range between 8 and 33 VDC. The horn shall utilize a mounting plate that allows the installer to pre-wire the mounting plate. The mounting plate shall be universal and mount on a single gang, double gang, octagon or 4 inch square box. If the horn is needed in a wet or outdoor installation, it shall be mounted on either a BBK-1 4" square back box or a BBX-5 outdoor matching back box. The horn shall have a gasket on the back plate that seals the electrical connection of the terminal connection. The mounting plate shall be completely covered by the horn and shall be secured by a single screw. Operating temperature range will be 32°F to 120°F (0°C to 49°C) for indoor model and -40°F to 151°F (-40°C to 66°C) for outdoor model. The horn shall be UL listed to standard 464, Audible Signaling Devices. In addition, the device shall be cUL listed to CAN-ULC S525.

Ordering Information

Model Number	Description	P/N
H-1224R	Select-A-Horn (red)	18645
BBK-1	Weatherproof Bell Backbox (red)	18865
BBX-5	Weatherproof Backbox (red)	99984

Note: Approvals/Listings maintained by and manufactured by Potter Electric Signal Company.

The seller makes no warranties, express or implied, including, but not limited to, the implied warranties of merchantability and fitness for a particular purpose, except as expressly stated in the seller's sales contract or sales acknowledgment form. Every attempt is made to keep our product information up-to-date and accurate. All specific applications cannot be covered, nor can all requirements be anticipated. All specifications are subject to change without notice.



1102 Rupcich Drive
Millennium Park
Crown Point, IN 46307
TEL: (219) 663-1600 FAX: (219) 663-4562
e-mail: info@janusfiresystems.com
www.janusfiresystems.com