



SURFACE MOUNT BOXES



1-gang

P/N: See Chart

Standard Features

- One and two gang
- Two standard colors
- Durable baked finish
- Sturdy steel one-piece construction
- Grounding provision
- Combination ½ inch & ¾ inch knockouts

Overview

Janus Fire Systems® Surface Mount Boxes are multi-gang utility boxes designed for surface mounting where a heavy-duty general purpose box is required. Devices can be mounted to pre-drilled and tapped (#6-32) holes in standard one-gang or two-gang mounting configurations.

The boxes are finished in a durable baking enamel and are available in two standard colors.

They are constructed from heavy duty 16 gauge cold rolled steel (CRS) for maximum durability. The boxes are easily surface mounted with screws using the mounting holes provided in the back of the box. All boxes are provided with convenient combination 1/2 inch and 3/4 inch conduit knockouts on the top, bottom and rear side. Each box also includes a grounding provision.

Applications

These surface mount boxes are suited for a variety of uses including:

- End-of-Line Resistors
- Manual Pull Stations
- CO2 Discharge Stations
- Signature Series Modules
- Clean Agent Discharge Stations



Dimensions

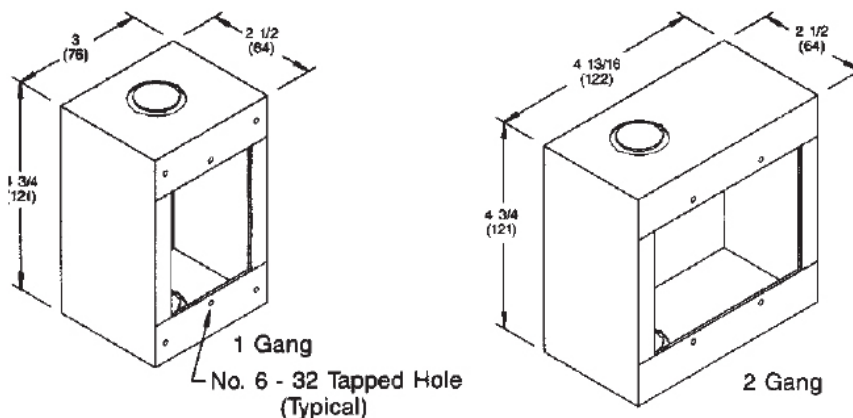

All dimensions are shown in inches (millimeters)

Install Ground Wire
between 8-32 Screw
PP07216-0000
& Shatterproof Washer
PP06677-0000

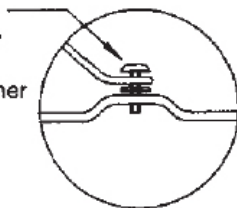

Ground Detail

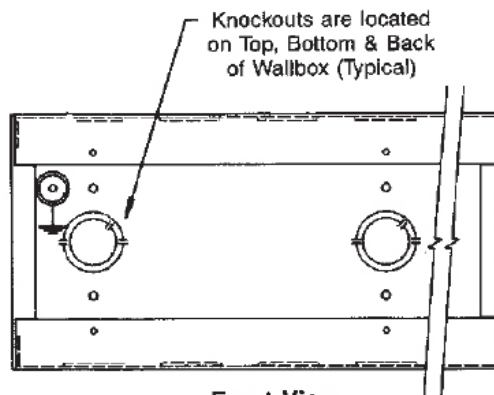

Front View

Ordering Information

P/N	Description	Ship Wt. lb (kg)
18888	1-gang, Fire Red	1.0 (0.5)
18889	1-gang, Bright White	1.0 (0.5)
18881	2-gang, Fire Red	2.0 (0.9)
18882	2-gang, Bright White	2.0 (0.9)

Note: Approvals/Listings maintained by and manufactured by General Electric Company.

The seller makes no warranties, express or implied, including, but not limited to, the implied warranties of merchantability and fitness for a particular purpose, except as expressly stated in the seller's sales contract or sales acknowledgment form. Every attempt is made to keep our product information up-to-date and accurate. All specific applications cannot be covered, nor can all requirements be anticipated. All specifications are subject to change without notice.



1102 Rucpich Drive
Millennium Park
Crown Point, IN 46307
TEL: (219) 663-1600 FAX: (219) 663-4562
e-mail: info@janusfiresystems.com
www.janusfiresystems.com