



GSA-PHS

INTELLIGENT 3D MULTISENSOR DETECTOR



Application Notes
Available

P/N: 18887

Standard Features

- Integrates photoelectric smoke and 135°F (57°C) fixed-temperature heat sensing technologies
- Non-volatile memory
- Automatic device mapping
- Electronic addressing
- Environmental compensation
- Integral microprocessor - intelligent detector
- Wide 0.67% to 3.77%/ft. sensitivity range
- Twenty pre-alarm sensitivity values, set in 5% increments
- Identification of dirty or defective detectors
- Automatic day/night sensitivity adjustment
- Twin RED/GREEN status LEDs
- Standard, relay, fault isolator, and audible mounting bases
- Designed and manufactured to ISO 9001 standards

Note: Some features described here may not be supported by all control systems. Check your control panel's Installation and Operation Guide for details.

Overview

The Signature Series Model GSA-PHS Intelligent 3D Multisensor Detector gathers analog information from each of its two fire sensing elements (photoelectric and heat) and converts it into digital signals. The detector's on-board microprocessor measures and analyzes these signals separately with respect to a third element - Time. We call this technology 3D. It compares the information to historical readings, time patterns, and several known fire characteristics to make an alarm decision. Digital filters remove signal patterns that are not typical of fires. Unwanted alarms are virtually eliminated.

Signature Series Overview

The microprocessor in each detector provides four additional benefits - Self-diagnostics and History Log, Automatic Device Mapping, Stand-alone Operation and Fast, Stable Communication.

Self-diagnostics and History Log - Each Signature Series detector constantly runs self-checks to provide important maintenance information. The results of the self-check are automatically updated and permanently stored in the detector's non-volatile memory. This information is accessible for review any time at the control panel, PC, or by using the SIGA-PRO Signature Program/Service Tool.

Automatic Device Mapping - The loop controller learns where each device's serial number address is installed relative to other devices on the circuit. This mapping feature provides supervision of each device's installed location to prevent a detector from being reinstalled (after cleaning etc.) in a different location from where it was originally. The history log for the detector remains relevant and intact regardless of its new location.



The Signature Series Data Entry Program also uses the mapping feature. With interactive menus and graphic support, the wired circuits between each device can be examined. Layout or “as-built” drawing information showing wire branches (T-taps), device types and their address are stored on disk for printing hard copy. This takes the mystery out of the installation. The preparation of as-built drawings is fast and efficient.

Stand-alone Operation - A decentralized alarm decision by the detector is guaranteed. On-board intelligence permits the detector to operate in stand-alone mode. If loop controller CPU communications fail for more than four seconds, all devices on that circuit go into stand-alone mode. The circuit acts like a conventional alarm receiving circuit. Each detector on the circuit continues to collect and analyze information from its surroundings. The detector alarms if the preset smoke obscuration level is reached or ambient temperature increases by 65°F (35°C).

Fast Stable Communication - On-board intelligence means less information needs to be sent between the detector and the loop controller. Other than regular supervisory polling response, the detector only needs to communicate with the loop controller when it has something new to report. This provides very fast control panel response time and allows a lower baud rate (speed) to be used for communication on the circuit.

Environmental Compensation - Detection sensitivity for the GSA-PHS is virtually independent of its installed environment and its physical condition. Environmental compensation means each sensing element adapts to long-term changes caused by dirt, humidity, temperature, aging etc. It even compensates for small amounts of normal ambient smoke. Approximately six times every hour, the detector adjusts and updates the sensitivity (% obscuration) and ambient temperature baselines for each sensing element. Signature Series environmental compensation is so reliable that it meets NFPA72 field sensitivity testing requirements — without the need for external meters.

Sensitivity Range - The GSA-PHS has a sensitivity range or window of 0.67 - 3.70% obscuration per foot. The installer selects the detector’s ALARM sensitivity level. Five settings ranging from the least sensitive at 3.5% obscuration/ft to the most sensitive at 1.0% obscuration/ft are available.

Automatic Day/Night Sensitivity Selection - Signature Series detectors may be programmed for different sensitivities during day and night periods. This allows the detector to be more sensitive during unoccupied periods when lower ambient background conditions are expected.

Stability - The 3D detector’s sensitivity remains stable in wind velocities up to 500 ft/min (2.53 m/sec). Ambient temperature has very little affect on the detector. The detector may be installed in rooms with ambient temperatures up to 100°F (38°C).

Electronic Addressing - The loop controller electronically addresses each detector, saving valuable time during system commissioning. Setting complicated switches or dials is not required. Each detector has its own unique serial number stored in its on-board memory. The loop controller identifies each device on the circuit and assigns a “soft” address to that device’s serial number. If desired, detectors can be addressed using the SIGA-PRO Signature Program/Service Tool.

Testing & Maintenance

Each detector automatically identifies when it is dirty or defective and causes a “dirty detector” message. The detector’s sensitivity measurement can also be transmitted to the loop controller. A sensitivity report can be printed to satisfy NFPA sensitivity measurements which must be conducted at the end of the first year and every two years thereafter.

The user-friendly maintenance program shows the current state of each detector and other pertinent messages. Single detectors may be turned off temporarily, from the control panel. Availability of maintenance features is dependent on the fire alarm system used. Scheduled maintenance (Regular or Selected) for proper detector operation should be planned to meet the requirements of the Authority Having Jurisdiction (AHJ). Refer to current NFPA 72 and ULC CAN/ULC 536 standards.

Compatibility

The GSA-PHS detectors are compatible only with Signature Loop Controllers.



Installation

Signature Series detectors mount to North American 1-gang boxes, 3-1/2 inch or 4 inch octagon boxes, 1-1/2 inches (38 mm) deep. They mount to European BESA and 1-gang boxes with 60.3 mm fixing centers.

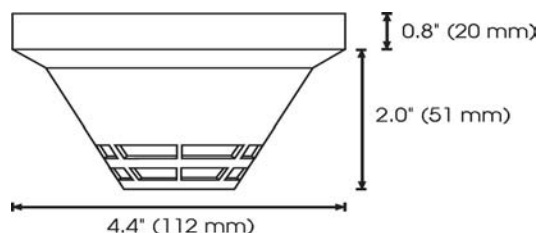
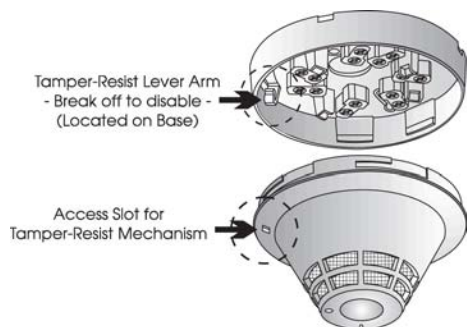

Application

Although photoelectric detectors have a wide range of fire sensing capabilities they are best suited for detecting slow, smoldering fires. The table below shows six standard test fires used to rate the sensitivity of smoke and heat detectors. The table indicates that no single sensing element is suited for all test fires.

Janus Fire Systems recommends that this detector be installed according to latest recognized edition of national and local fire alarm codes.

Test Fire	GSA-IS Ion P/N 18653	GSA-PS Photo P/N 18654	Detect-A-Fire Heat (See DS1022)	GSA-PHS Photo Heat 3D P/N 18887	GSA-IPHS Ion/ Photo/Heat 4D P/N 18655
Open Wood	optimum	unsuitable	optimum	very suitable	optimum
Wood Pyrolysis	suitable	optimum	unsuitable	optimum	optimum
Smouldering Cotton	very suitable	optimum	unsuitable	optimum	optimum
Poly Urethane Foam	very suitable	very suitable	suitable	very suitable	optimum
n-Heptane	optimum	very suitable	very suitable	optimum	optimum
Liquid Fire without Smoke	unsuitable	unsuitable	optimum	very suitable	very suitable



Typical Wiring

The detector mounting bases accept #18 AWG (0.75 mm²), #16 (1.0 mm²), #14 AWG (1.5 mm²), and #12 AWG (2.5 mm²) wire sizes.

Note: Sizes #16 AWG (1.0 mm²) and #18 AWG (0.75 mm²) are preferred for ease of installation. See Signature Loop Controller catalog sheet for detailed wiring requirement specifications.

Standard Detector Base, GSA-SB

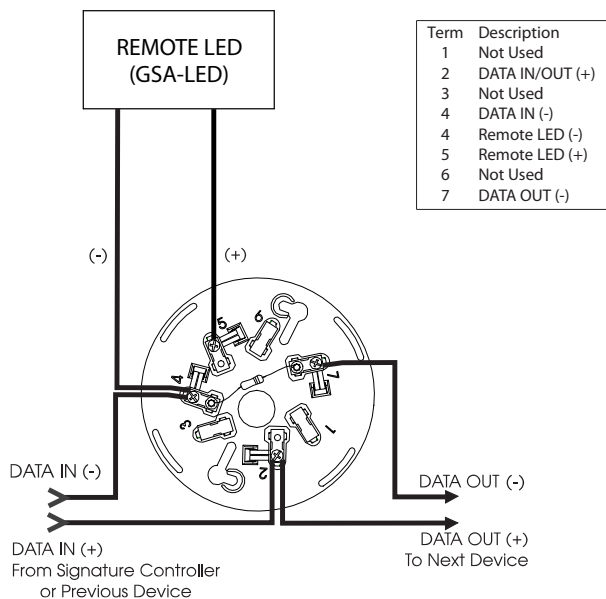

Relay Detector Base, GSA-RB

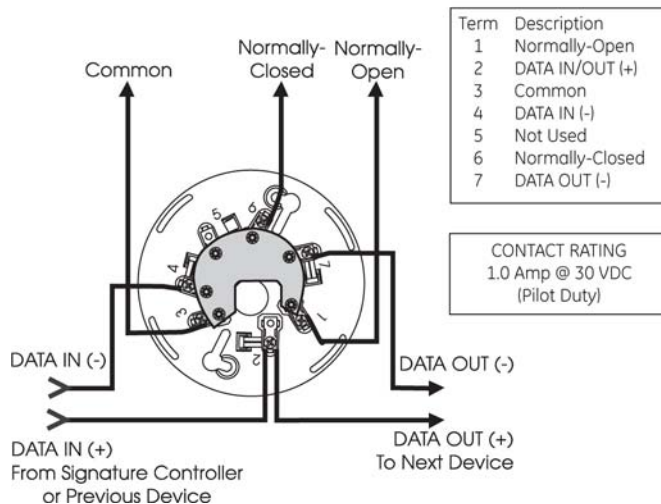



Isolator Detector Base, GSA-IB

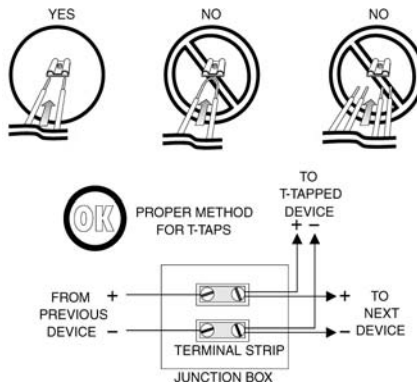
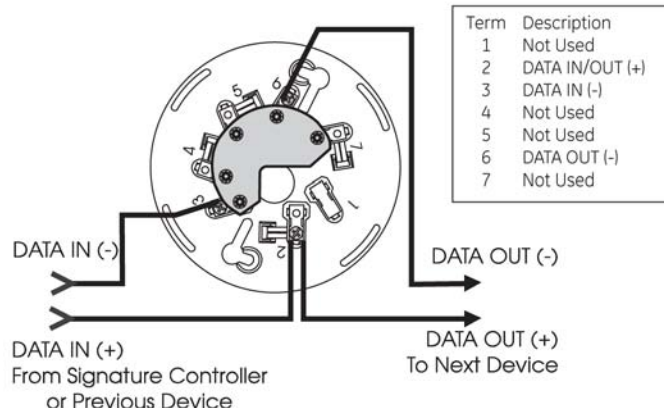

Warnings and Cautions

This detector will not operate without electrical power. As fires frequently cause power interruption, we suggest you discuss further safeguards with your fire protection specialist.

This detector will NOT sense fires that start in areas where smoke or heat cannot reach the detector. Smoke from fires in walls, roofs, or on the opposite side of closed doors may not reach the detector to alarm it.

The heat sensor in this device only provides a source of information to supplement the information provided by the photoelectric smoke sensor. The heat sensor by itself does NOT protect life against fire and smoke.



Accessories

All detector mounting bases have wiring terminals that are accessible from the “room-side” after mounting the base to the electrical box. The bases mount to North American 1-gang boxes and to 3½ inch or 4 inch octagon boxes, 1½ inches (38 mm) deep. They also mount to European BESA and 1-gang boxes with 60.3 mm fixing centers.



Standard Base GSA-SB - This is the basic mounting base for Signature Series detectors. The GSA-LED Remote LED is supported by the Standard Base.

Relay Base GSA-RB - This base includes a relay. Normally open or closed operation is selected during installation. The dry contact is rated for one amp (pilot duty) @ 30 VDC. The relay’s position is supervised to avoid accidentally jarring it out of position. The GSA-RB can be operated as a control relay if programmed to do so at the control panel (V. 2 only). The relay base does not support the GSA-LED Remote LED.

Relay Bases operate as follows:

- at system power-up or reset, the relay is de-energized
- when a detector is installed in the base with the power on, the relay energizes for four seconds, then de-energizes
- when a detector is removed from a base with the power on, the relay is de-energized
- when the detector enters the alarm state, the relay is energized.

Isolator Base GSA-IB - This base includes a built-in line fault isolator for use on Class A circuits. A detector must be installed for it to operate. The isolator base does not support the GSA-LED Remote LED.

The isolator operates as follows:

- a short on the line causes all isolators to open within 23 msec.
- at 10 msec intervals, beginning on one side of the Class A circuit nearest the loop controller, the isolators close to provide the next isolator down the line with power.
- when the isolator next to the short closes, it reopens within 10 msec.

The process repeats beginning on the other side of the loop controller.

Remote LED GSA-LED - The remote LED connects to the GSA-SB Standard Base only. It features a North American size 1-gang plastic faceplate with a white finish and red alarm LED.



Specifications

Smoke Sensing Element	Photoelectric - Light Scattering Principle
Heat Sensing Element	Fixed Temperature Alarms at 135°F (57°C) Ambient
Operating and Storage Environment	Operating Temp: 32°F to 100°F (0°C to 38°) Storage Temp: -4°F to 140°F (-20°C to 60°C) Humidity: 0 to 93% RH, Non-Condensing
Sensitivity Range	ULI/ULC - 0.67% to 3.70%
User Selected Alarm Sensitivity Settings	Most Sensitive: 1.0%/ft. More Sensitive: 2.0%/ft. Normal: 2.5%/ft. Less Sensitive: 3.0%/ft Least Sensitive: 3.5%/ft.
Pre-alarm Sensitivity	5% increments, allowing up to 20 pre-alarm settings
Operating Voltage	15.2 to 19.95 VDC (19 VDC nominal)
Operating Current	Quiescent: 45 µA @ 19 V Alarm: 45 µA @ 19 V Emergency Stand-alone Alarm Mode: 18mA Pulse Current: 100 µA (100 msec) During Communication: 9mA maximum
Construction & Finish	High-Impact Engineering Polymer - White
Compatible Mounting Bases	GSA-SB Standard Base, GSA-RB Relay Base, GSA-IB Isolator Base
LED Operation	On-board Green LED - Flashes when polled On-board Red LED - Flashes when in alarm Both LEDs - Glow steady when in alarm (stand-alone) Compatible Remote Red LED (model GSA-LED) Flashes when in alarm
Compatibility	Use With Signature Loop Controller
Address Requirements	Uses one Device Address
UL Listed Spacing	30 ft.



Ordering Information

Model	P/N	Description	Ship Wt. lb (kg)
GSA-PHS	18887	Intelligent 3D Multisensor Detector	0.5 (.2)

Accessories

GSA-SB	18656	Detector Mounting Base	0.2 (0.1)
GSA-RB	18658	Detector Mounting Base w/Relay	0.2 (0.1)
GSA-IB	18657	Detector Mounting Base w/Fault Isolator	0.2 (0.1)
GSA-LED	18883	Remote Alarm LED	0.2 (0.1)
GSA-TS	18659	Trim Skirt (optional)	0.1 (0.05)

Note: Approvals/Listings maintained by and manufactured by General Electric Company.

The seller makes no warranties, express or implied, including, but not limited to, the implied warranties of merchantability and fitness for a particular purpose, except as expressly stated in the seller's sales contract or sales acknowledgment form. Every attempt is made to keep our product information up-to-date and accurate. All specific applications cannot be covered, nor can all requirements be anticipated. All specifications are subject to change without notice.



1102 Rucpich Drive
 Millennium Park
 Crown Point, IN 46307
 TEL: (219) 663-1600 FAX: (219) 663-4562
 e-mail: info@janusfiresystems.com
www.janusfiresystems.com