



# GSA-IPHS

## INTELLIGENT 4D MULTISENSOR DETECTOR



Application Notes  
Available

P/N: 18655

### Overview

People detect danger by relating many observations to one another and comparing them to familiar patterns. The simultaneous use of multiple senses allow humans to filter out situations which are not dangerous. The ability to detect danger depends largely on intelligence and knowledge from past experience; 4D detectors provide both.

The GSA-IPHS Intelligent 4D Multisensor Detector gathers analog information from each of its three fire sensing elements (ionization, photoelectric, and heat) and converts it into digital signals. The detector's on-board microprocessor measures and analyzes these signals separately with respect to a fourth element - Time. We call this technology 4D. It compares the information to historical readings, time patterns and several known fire characteristics to make an alarm decision. Digital filters remove signal patterns that are not typical of fires. Unwanted alarms are virtually eliminated.

### Standard Features

- Integrates three sensing technologies**  
Processes and analyzes information from each sensor (ion/photo/heat) separately using dynamic filters then applies a sophisticated algorithm for optimum detection accuracy.
- Non-volatile memory**  
Permanently stores serial number, type of device, and job number. Automatically updates historic information including hours of operation, last maintenance date, number of alarms and troubles, time of last alarm, and analog signal patterns for each sensing element just before last alarm.
- Automatic device mapping**  
Each detector transmits wiring information regarding its location with respect to other devices on the circuit. Detectors installed in the wrong location during cleaning are automatically reported to the loop controller.
- Electronic addressing**  
Permanently stores programmable address; there are no switches or dials to set. Addresses are downloaded from a PC, or the SIGA-PRO Signature Program/Service Tool.
- Environmental compensation**  
Each sensing element self-compensates for changes in the detector's installed environment to maintain the sensitivity setting and prevent unwanted alarms. The detector reports when it cannot compensate any further.
- Integral microprocessor — Intelligent detector**  
All decisions are made at the detector allowing lower communication speed while substantially improving control panel response time. Less sensitive to line noise and loop wiring properties; twisted or shielded wire is not required.
- Wide 0.67 — 3.70%/ft. sensitivity range window**  
Program the detector to operate at any one of five sensitivity settings within the window.
- Pre-alarm**  
Detector stores one of 20 pre-alarm sensitivity values to alert local personnel prior to the sensor reaching a full evacuation sensitivity. Sensitivity values can be set in 5% increments.
- Identification of dirty or defective detector**  
Self-diagnostic and sensitivity check provides a dirty detector signal.
- Automatic day/night sensitivity adjustment**  
Makes detector more sensitive during inactive night-time periods.
- Stand-alone operation**  
The detector makes decisions and inputs an alarm even if the loop controller fails. The detector reverts to an intelligent "conventional" detector when polling interrogation stops.



- **Stable design**  
Sensitivity remains stable with air velocity up to 500 ft/min (2.53m/sec) making it suitable for direct insertion in low velocity duct applications.
- **Designed for high ambient temperature operation**  
Install in ambient temperatures up to 100°F (38°C).
- **Twin status LEDs**  
Flashing GREEN shows normal; flashing RED shows alarm state; steady RED and steady GREEN show alarm state in stand alone mode, visible from any direction.
- **Standard, relay, and fault isolator mounting bases**  
Three mounting bases provide clamp terminals, allow room side wiring and include an optional tamper-resist feature.
- **Designed to ISO 9001 standards**  
Manufactured to strict international quality standards for highest reliability.

**Note:** *Some features described here may not be supported by all control systems. Check your control panel's Installation and Operation Guide for details.*

## Signature Series Overview

The microprocessor in each detector provides four additional benefits - Self-diagnostics and History Log, Automatic Device Mapping, Stand-alone Operation and Fast, Stable Communication.

**Self-diagnostics and History Log** - Each Signature Series detector constantly runs self-checks to provide important maintenance information. The results of the self-check are automatically updated and permanently stored in the detector's non-volatile memory. This information is accessible for review any time at the control panel, PC, or by using the SIGA-PRO Signature Program/Service Tool.

**Automatic Device Mapping** - The loop controller learns where each device's serial number address is installed relative to other devices on the circuit. This mapping feature provides supervision of each device's installed location to prevent a detector from being reinstalled (after cleaning etc.) in a different location from where it was originally. The history log for the detector remains relevant and intact regardless of its new location.

The Signature Series Data Entry Program also uses the mapping feature. With interactive menus and graphic support, the wired circuits between each device can be examined. Layout or "as-built" drawing information showing wire branches (T-taps), device types and their address are stored on disk for printing hard copy. This takes the mystery out of the installation.

The preparation of as-built drawings is fast and efficient.

**Stand-alone Operation** - A decentralized alarm decision by the detector is guaranteed. On-board intelligence permits the detector to operate in stand-alone mode. If loop controller CPU communications fail for more than four seconds, all devices on that circuit go into stand-alone mode. The circuit acts like a conventional alarm receiving circuit. Each detector on the circuit continues to collect and analyze information from its surroundings. The detector alarms if the preset smoke obscuration level is reached or ambient temperature increases by 65°F (35°C). If the detector is mounted to a relay base, the relay operates.

**Fast Stable Communication** - On-board intelligence means less information needs to be sent between the detector and the loop controller. Other than regular supervisory polling response, the detector only needs to communicate with the loop controller when it has something new to report. This provides very fast control panel response time and allows a lower baud rate (speed) to be used for communication on the circuit.

**Environmental Compensation** - Detection sensitivity for the GSA-IPHS is virtually independent of its installed environment and its physical condition. Environmental compensation means each sensing element adapts to long-term changes caused by dirt, humidity, temperature, aging etc. It even compensates for small amounts of normal ambient smoke. Approximately six times every hour, the detector adjusts and updates the sensitivity (% obscuration) and ambient temperature baselines for each sensing element. *Signature Series environmental compensation is so reliable that it meets NFPA72 field sensitivity testing requirements — without the need for external meters.*

**Sensitivity Range** - The GSA-IPHS has a sensitivity range or window of 0.67 - 3.70% obscuration per foot. The installer selects the detector's ALARM sensitivity level. Five settings ranging from the least sensitive at 3.5% obscuration/ft to the most sensitive at 1.0% obscuration/ft are available.

**Pre-Alarm** - Pre-alarm warnings may alert local staff to a possible fire condition allowing them to investigate before entering into a full alarm condition which requires building evacuation. The 4D multisensor's wide sensitivity range permits the use of early warning pre-alarm values. The pre-alarm value can be set by the user in 5% increments, allowing up to 20 pre-alarm settings.



**Automatic Day/Night Sensitivity Selection** - Signature Series detectors may be programmed for different sensitivities during day and night periods. This allows the detector to be more sensitive during unoccupied periods when lower ambient background conditions are expected.

**Stability** - The 4D detector's sensitivity remains stable in wind velocities up to 500 ft/min (2.53 m/sec). Ambient temperature has very little affect on the detector. The detector may be installed in rooms with ambient temperatures up to 100°F (38°C).

**Status LEDs** - Twin LEDs are visible from any direction. A flashing GREEN LED shows normal system polling from the loop controller. A flashing RED LED means the detector is in alarm state. Both LEDs on steady shows alarm state - stand-alone mode. Normal GREEN LED activity is not distracting to building occupants, but can be quickly spotted by a maintenance technician.

**Electronic Addressing** - The loop controller electronically addresses each detector, saving valuable time during system commissioning. Setting complicated switches or dials is not required. Each detector has its own unique serial number stored in its on-board memory. The loop controller identifies each device on the circuit and assigns a "soft" address to that device's serial number.

### Application

With intelligent 4D multisensor detectors, unwanted alarms go down to nearly zero and the detection of all types of fire increases to nearly 100%. The European standard DIN EN 54 part 9 describes six standard test fires used to rate the sensitivity of heat, ionization, and photoelectric smoke detectors. No single sensing element is equally suitable for all test fires.

The table below shows that the 4D detector is suited for all applications. Normal detector spacing guidelines should be followed.

GSA-IPHS detectors are compatible only with Signature Loop Controllers.

Test Fire	GSA-IS Ion P/N 18653	GSA-PS Photo P/N 18654	Detect-A-Fire Heat (See DS1022)	GSA-PHS Photo Heat 3D P/N 18887	GSA-IPHS Ion/ Photo/Heat 4D P/N 18655
Open Wood	optimum	unsuitable	optimum	very suitable	optimum
Wood Pyrolysis	suitable	optimum	unsuitable	optimum	optimum
Smouldering Cotton	very suitable	optimum	unsuitable	optimum	optimum
Poly Urethane Foam	very suitable	very suitable	suitable	very suitable	optimum
n-Heptane	optimum	very suitable	very suitable	optimum	optimum
Liquid Fire without Smoke	unsuitable	unsuitable	optimum	very suitable	very suitable

Depending on the type of fire expected in a protected space, the designer usually chooses from three types of sensor technology. Ionization sensors respond well to fast, flaming fires. Photoelectric sensors respond well to smoldering fires, and heat sensors are used as backup or in environmentally poor atmospheres for smoke detection. Agency requirements demand that ionization sensors respond to smoldering fires and that photoelectric sensors respond to flaming fires. This makes single element sensors more prone to false alarms and slow to respond to fires that are difficult for them to detect. Only when ALL three fire sensing elements — Ionization, Photoelectric and Heat — are suitably combined into one detector can ALL types of fires be effectively detected while virtually eliminating false alarms.

When 4D multisensor detectors are installed, a fire alarm system does not have to be altered when the application or the type of "expected" fire changes. The guesswork is removed. The GSA-IPHS 4D detector is suited for all fire detection applications.



## Installation

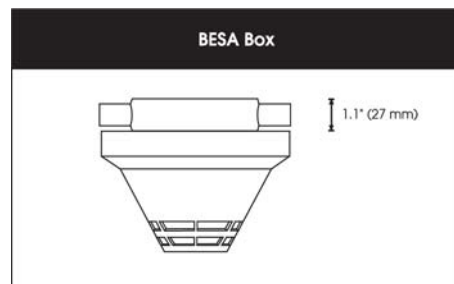
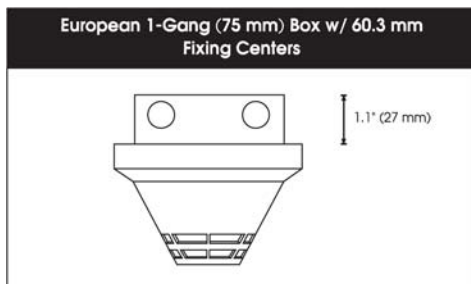
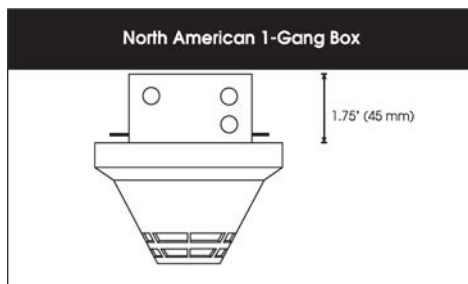
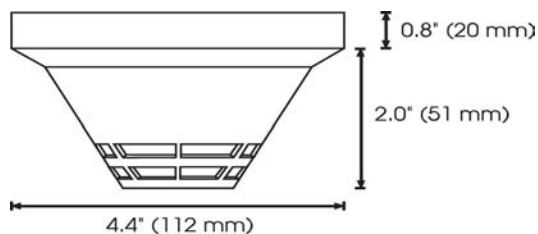
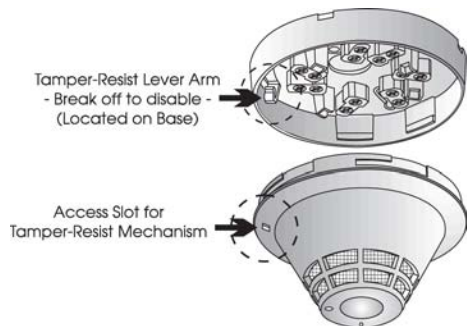

## Typical Wiring

The detector mounting bases accept #18 AWG (0.75 mm<sup>2</sup>), #16 AWG (1.0 mm<sup>2</sup>), #14 AWG (1.5 mm<sup>2</sup>), and #12 AWG (2.5 mm<sup>2</sup>) wire sizes.

Note: Sizes #16 AWG (1.0 mm<sup>2</sup>) and #18 AWG (0.75 mm<sup>2</sup>) are preferred for ease of installation. See Signature Loop Controller catalog sheet for detailed wiring requirement specifications.

### Standard Detector Base, GSA-SB

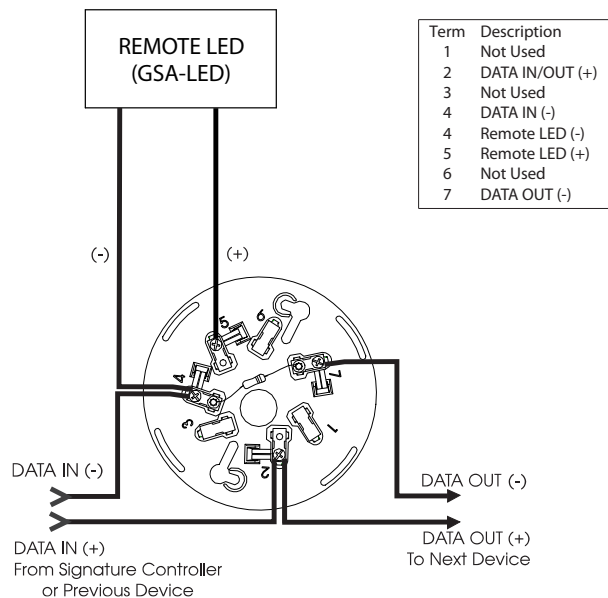



## Relay Detector Base, GSA-RB

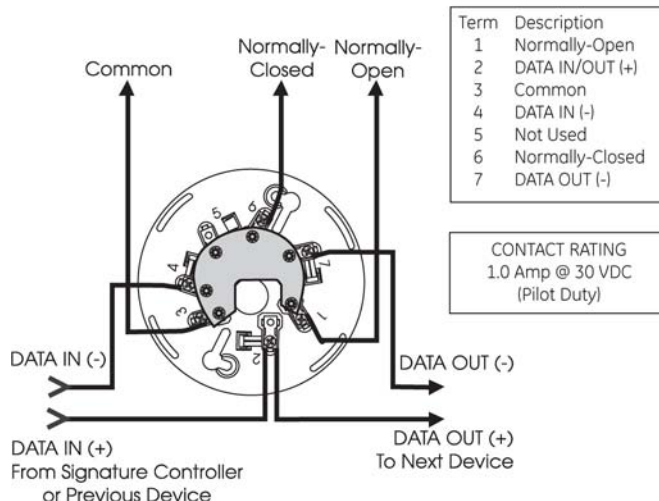

## Isolator Detector Base, GSA-IB

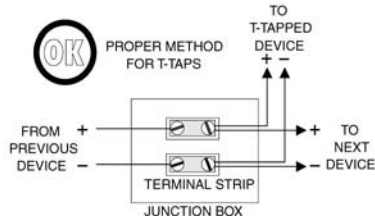
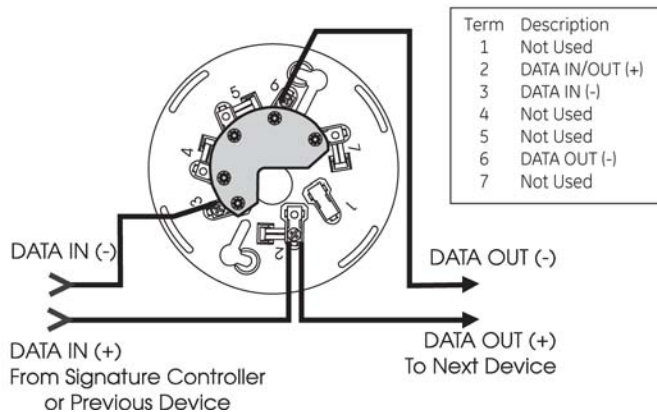



## Warnings and Cautions

This detector will not operate without electrical power. As fires frequently cause power interruption, we suggest you discuss further safeguards with your fire protection specialist.

This detector will NOT sense fires that start in areas where smoke or heat cannot reach the detector. Smoke or heat from fires in walls, roofs, or on the opposite side of closed doors may not reach the detector to alarm it.

The heat sensor in this device only provides a source of information to supplement the information provided by the ionization and photoelectric smoke sensors. The heat sensor by itself does NOT protect life against fire and smoke.

## Accessories

All detector mounting bases have wiring terminals that are accessible from the “room-side” after mounting the base to the electrical box. The bases mount to North American 1-gang boxes and to 3½ inch or 4 inch octagon boxes, 1½ inches (38 mm) deep. They also mount to European BESA and 1-gang boxes with 60.3 mm fixing centers.



**Standard Base GSA-SB** - This is the basic mounting base for Signature Series detectors. The GSA-LED Remote LED is supported by the Standard Base.

**Relay Base GSA-RB** - This base includes a relay. Normally open or closed operation is selected during installation. The dry contact is rated for 1 amp (pilot duty) @ 30 VDC. The relay’s position is supervised to avoid accidentally jarring it out of position. The GSA-RB can be operated as a control relay if programmed to do so at the control panel ( V. 2 only). The relay base does not support the GSA-LED Remote LED.

Relay Bases operate as follows:

- at system power-up or reset, the relay is de-energized.
- when a detector is installed in the base with the power on, the relay energizes for four seconds, then de-energizes.
- when a detector is removed from a base with the power on, the relay is de-energized.

## Testing & Maintenance

Each detector automatically identifies when it is dirty or defective and causes a “dirty detector” message. The detector’s sensitivity measurement can also be transmitted to the loop controller. A sensitivity report can be printed to satisfy NFPA sensitivity measurements which must be conducted at the end of the first year and every two years thereafter.

The user friendly maintenance program shows the current state of each detector and other pertinent messages. Single detectors may be turned off temporarily, from the control panel. Availability of maintenance features is dependent on the fire alarm system used.

Scheduled maintenance (Regular or Selected) for proper detector operation should be planned to meet the requirements of the Authority Having Jurisdiction (AHJ). Refer to current NFPA 72 and ULC CAN/ULC 536 standards.

- when the detector enters the alarm state, the relay is energized.

**Isolator Base GSA-IB**, - This base includes a built-in line fault isolator for use on Class A circuits. A detector must be installed for it to operate. The isolator base does not support the GSA-LED Remote LED.

The isolator operates as follows:

- a short on the line causes all isolators to open within 23 msec
- at 10 msec intervals, beginning on one side of the Class A circuit nearest the loop controller, the isolators close to provide the next isolator down the line with power
- when the isolator next to the short closes, it reopens within 10 msec.

The process repeats beginning on the other side of the loop controller.

**Remote LED GSA-LED** - The remote LED connects to the GSA-SB Standard Base only. It features a North American size 1-gang plastic faceplate with a white finish and red alarm LED.



Specifications	
Ion Sensor	(unipolar) 0.135 $\mu$ C Americium 241
Photo Sensor	Light Scattering Principle
Heat Sensor	Alarms at 65°F (35°C) above ambient
Storage and Operating Environment	Air Velocity Range: 0 to 500 ft/min (0 to 2.53 m/s) Operating Temperature: 32°F to 100°F (0°C to 38°C) Storage Temperature: -4°F to 140°F (-20°C to 60°C) Humidity: 0 to 93% RH, Non-condensing Altitude: 6,000 ft. (1828m) above sea level maximum
Sensitivity Range	ULI/ULC - 0.67% to 3.70% obscuration/foot
User Selected Alarm Sensitivity Settings	Most Sensitive: 1.0%/ft. More Sensitive: 2.0%/ft. Normal: 2.5%/ft. Less Sensitive: 3.0%/ft. Least Sensitive: 3.5%/ft.
Pre-alarm Sensitivity	5% increments, allowing up to 20 pre-alarm settings
Operating Voltage	15.2 to 19.95 VDC (19 VDC nominal)
Operating Current	Quiescent: 45 $\mu$ A @ 19 V Alarm: 45 $\mu$ A @ 19 V Emergency Stand-alone Alarm Mode: 18mA Pulse Current: 100 $\mu$ A (100 msec)
Construction & Finish	High-Impact Engineering Polymer - White or Black
Compatible Mounting Bases	GSA-SB Standard Base, GSA-RB Relay Base, GSA-IB Isolator Base
LED Operation	On-board Green LED - Flashes when polled On-board Red LED - Flashes when in alarm Both LEDs - Glow steady when in alarm (stand-alone) Compatible Remote Red LED (model GSA-LED) Flashes when in alarm
Compatibility	Use With Signature Loop Controller
Address Requirements	Uses one Device Address
UL Listed Spacing	30 ft.



**Ordering Information**

Model	P/N	Description	Ship Wt. lb (kg)
GSA-IPHS	18655	Intelligent 4D Multisensor Detector	0.5 (.2)

**Accessories**

GSA-SB	18656	Detector Mounting Base	0.2 (0.1)
GSA-RB	18658	Detector Mounting Base w/Relay	0.2 (0.1)
GSA-IB	18657	Detector Mounting Base w/Fault Isolator	0.2 (0.1)
GSA-LED	18883	Remote Alarm LED	0.2 (0.1)
GSA-TS	18659	Trim Skirt (optional)	0.1 (.05)

*Note: Approvals/Listings maintained by and manufactured by General Electric Company.*

The seller makes no warranties, express or implied, including, but not limited to, the implied warranties of merchantability and fitness for a particular purpose, except as expressly stated in the seller's sales contract or sales acknowledgment form. Every attempt is made to keep our product information up-to-date and accurate. All specific applications cannot be covered, nor can all requirements be anticipated. All specifications are subject to change without notice.



1102 Rupcich Drive  
 Millennium Park  
 Crown Point, IN 46307  
 TEL: (219) 663-1600 FAX: (219) 663-4562  
 e-mail: [info@janusfiresystems.com](mailto:info@janusfiresystems.com)  
[www.janusfiresystems.com](http://www.janusfiresystems.com)