

GSA-CT/MCT SERIES

INPUT MODULES



Application Notes
Available

P/N: See Chart

Standard Features

- **Multiple applications**
Including Alarm, Alarm with delayed latching (retard) for waterflow applications, Supervisory, and Monitor. The installer selects one of four “personality codes” to be downloaded to the module through the loop controller.
- **Plug-in (UIO) or standard 1-gang mount**
UIO versions allow quick installation where multiple modules are required. The 1-gang mount version is ideal for remote locations that require a single module.
- **Automatic device mapping**
Signature modules transmit information to the loop controller regarding their circuit locations with respect to other Signature devices on the wire loop.
- **Electronic addressing**
Programmable addresses are downloaded from the loop controller, a PC, or the SIGA-PRO Signature Program/Service Tool. There are no switches or dials to set.
- **Non-volatile memory**
Permanently stores serial number, type of device, and job number.
- **Stand-alone operation**
The module makes decisions and inputs an alarm from initiating devices connected to it even if the loop controller’s polling interrogation stops. (Function availability dependent upon control panel.)
- **Ground fault detection by address**
Detects ground faults right down to the device level.

Overview

The GSA-CT1 Single Input Module and GSA-CT2/GSA-MCT2 Dual Input Modules are intelligent analog addressable devices used to connect one or two Class B normally-open Alarm, Supervisory, or Monitor type dry contact Initiating Device Circuits (IDC).

The actual function of these modules is determined by the “personality code” selected by the installer. This code is downloaded to the module from the Signature loop controller during system configuration.

The input modules gather analog information from the initiating devices connected to them and convert it into digital signals. The module’s on-board microprocessor analyzes the signal and decides whether or not to input an alarm.

The **GSA-CT1** and **GSA-CT2** mount to standard North American 1-gang electrical boxes, making them ideal for locations where only one module is required. Separate I/O and data loop connections are made to each module.

The **GSA-MCT2** is part of the UIO family of plug-in Signature Series modules. It functions identically to the GSA-CT2, but takes advantage of the modular flexibility and easy installation that characterizes all UIO modules. Two- and six-module UIO motherboards are available. All wiring connections are made to terminal blocks on the motherboard. UIO assemblies may be mounted in Janus Fire Systems® enclosures.



Signature Series Overview

The Signature Series intelligent analog-addressable system from Janus Fire Systems is an entire family of multi-sensor detectors and mounting bases, multiple-function input and output modules, network and non-network control panels, and user-friendly maintenance and service tools. Analog information from equipment connected to Signature devices is gathered and converted into digital signals. An onboard microprocessor in each Signature device measures and analyzes the signal and decides whether or not to input an alarm. The microprocessor in each Signature device provides four additional benefits – Self-diagnostics and History Log, Automatic Device Mapping, Stand-alone Operation and Fast, Stable Communication.

Self-diagnostics and History Log – Each Signature Series device constantly runs self-checks to provide important maintenance information. The results of the self-check are automatically updated and permanently stored in its non-volatile memory. This information is accessible for review any time at the control panel, PC, or using the SIGA-PRO Signature Program/Service Tool.

Automatic Device Mapping – The Signature Data Controller (SDC) learns where each device's serial number address is installed relative to other devices on the circuit. The SDC keeps a map of all Signature Series devices connected to it. The Signature Series Data Entry Program also uses the mapping feature. With interactive menus and graphic support, the wired circuits between each device can be examined. Layout or “as-built” drawing information showing branch wiring (T-taps), device types and their address are stored on disk for printing hard copy.

Installation

GSA-CT1 and GSA-CT2: modules mount to North American 2½ inch (64 mm) deep 1-gang boxes and 1½ inch (38 mm) deep 4 inch square boxes with 1-gang covers and GSA-MP mounting plates (see DS1041). The terminals are suited for #12 to #18 AWG (2.5 mm² to 0.75 mm²) wire size.

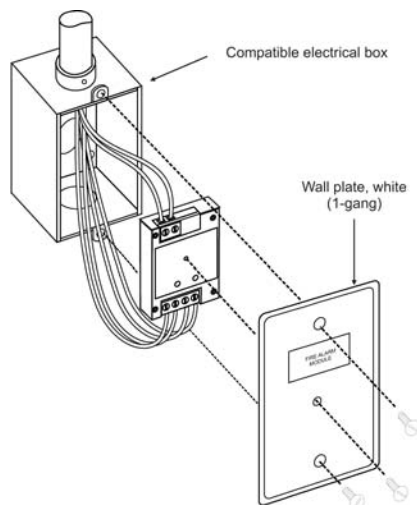

GSA-MCT2: mount the UIO motherboard inside a suitable Janus Fire Systems® enclosure with screws and washers provided. Plug the GSA-MCT2 into any available position on the motherboard and secure the module to the motherboard with the captive screws. Wiring connections are made to the terminals on the motherboard (see wiring diagram). UIO motherboard terminals are suited for #12 to #18 AWG (2.5 mm² to 0.75 mm²) wire size.

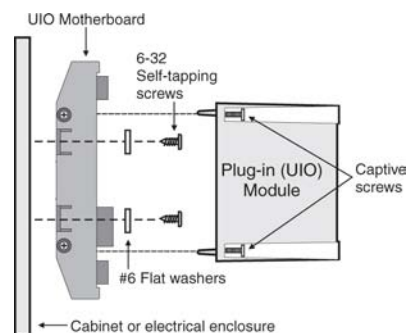

Electronic Addressing - The loop controller electronically addresses each module, saving valuable time during system commissioning. Setting complicated switches or dials is not required. Each module has its own unique serial number stored in its on-board memory. The loop controller identifies each device on the loop and assigns a “soft” address to each serial number.

Janus Fire Systems recommends that this module be installed according to latest recognized edition of national and local fire alarm codes.



Application

The duty performed by the GSA-CT1 and GSA-CT2/MCT2 is determined by their sub-type code or “Personality Code”. The code is selected by the installer depending upon the desired application and is downloaded from the loop controller.

One personality code can be assigned to the GSA-CT1. Two personality codes can be assigned to the GSA-CT2/MCT2. Codes 1, 2, 3 and 4 can be mixed on GSA-CT2/MCT2 modules only. For example, personality code 1 can be assigned to the first address (circuit A) and code 4 can be assigned to the second address (circuit B).

NORMALLY-OPEN ALARM - LATCHING (Personality Code 1) - Assign to one or both circuits. Configures either circuit A or B or both for Class B normally open dry contact initiating devices such as Pull Stations, Heat Detectors, etc. An ALARM signal is sent to the loop controller when the input contact is closed. The alarm condition is latched at the module.

NORMALLY-OPEN ALARM - DELAYED LATCHING (Personality Code 2) - Assign to one or both circuits. Configures either circuit A or B or both for Class B normally-open dry contact initiating devices such as Waterflow Alarm Switches. An ALARM signal is sent to the loop controller when the input contact is closed for approximately 16 seconds. The alarm condition is latched at the module.

NORMALLY-OPEN ACTIVE - NON-LATCHING (Personality Code 3) - Assign to one or both circuits. Configures either circuit A or B or both for Class B normally-open dry contact monitoring input such as from Fans, Dampers, Doors, etc. An ACTIVE signal is sent to the loop controller when the input contact is closed. The active condition is not latched at the module.

NORMALLY-OPEN ACTIVE - LATCHING (Personality Code 4) - Assign to one or both circuits. Configures either circuit A or B or both for Class B normally open dry contact monitoring input such as from Supervisory and Tamper Switches. An ACTIVE signal is sent to the loop controller when the input contact is closed. The active condition is latched at the module.

Warnings & Cautions

This module will not operate without electrical power. As fires frequently cause power interruption, we suggest you discuss further safeguards with your local fire protection specialist.

Compatibility

The Signature Series modules are compatible only with Signature Loop Controllers.

Typical Wiring

Modules will accept #18 AWG (0.75 mm²), #16 (1.0 mm²), and #14AWG (1.50 mm²), and #12 AWG (2.50 mm²) wire sizes.

Note: Sizes #16 AWG (1.0 mm²) and #18 AWG (0.75 mm²) are preferred for ease of installation. See Signature Loop Controller catalog sheet for detailed wiring requirement specifications.

Initiating (Slave) Device Circuit Wire Specifications	
Maximum Allowable Wire Resistance	50 ohms (25 ohms per wire) per Circuit
Maximum Allowable Wire Capacitance	0.1 µF per Circuit
For Design Reference	
Wire Size	Maximum Distance to EOLR
#18 AWG (0.75 mm ²)	4,000 ft (1,219 m)
#16 AWG (1.00 mm ²)	6,000 ft (1,829 m)
#14 AWG (1.50 mm ²)	9,000 ft (2,743 m)
#12 AWG (1.50 mm ²)	15,000 ft (4,572 m)

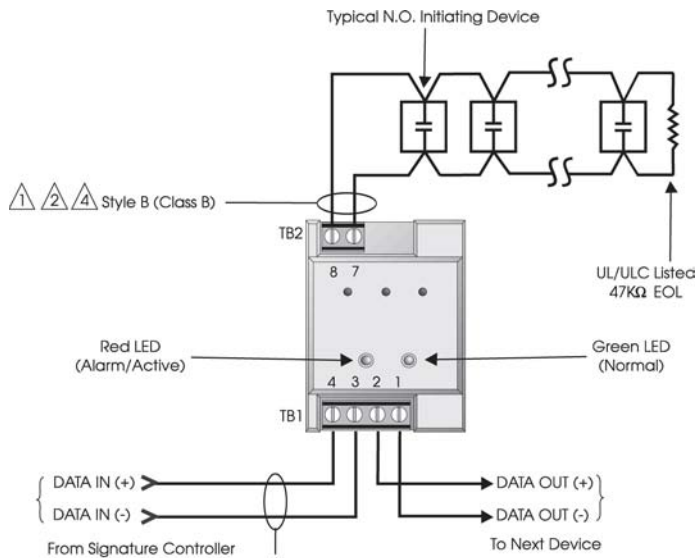

GSA-CT1

NOTES

- 1 Maximum 25 Ohm resistance per wire.
- 2 Maximum #12 AWG (2.5 mm²) wire; Minimum #18 AWG (0.75 mm²).
- 3 Refer to Signature controller installation sheet for wiring specifications.
- 4 Maximum 10 Vdc @ 350 μA
- 5 The GSA-UIO6R and the GSA-UIO2R do not come with TB14.
- 6 All wiring is supervised and power-limited.
- 7 These modules will not support 2-wire smoke detectors.

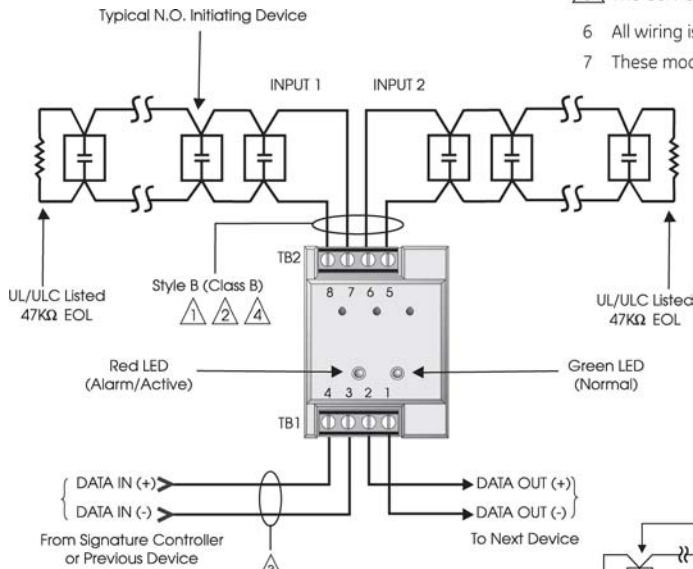

GSA-CT2

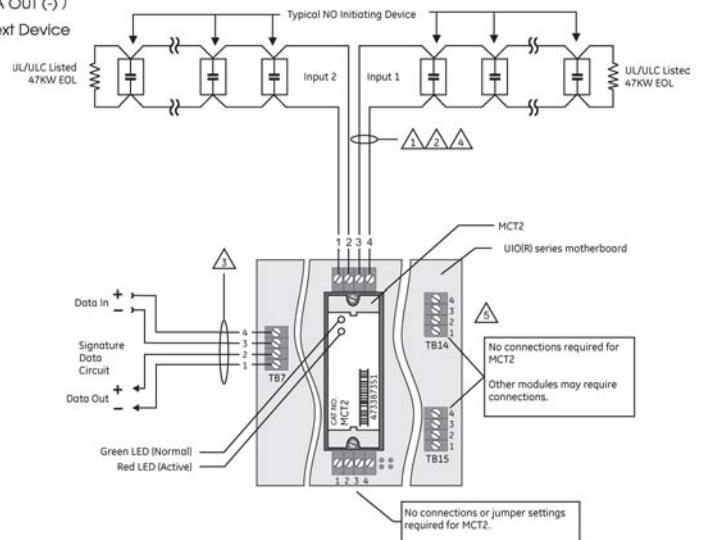

GSA-MCT2



Specifications

Catalog Number	GSA-CT1	GSA-CT2	GSA-MCT2
Description	Single Input Module	Dual Input Module	
Type Code	48 (factory set) Four sub-types (personality codes) are available	49 (factory set) Four sub-types (personality codes) are available	
Address Requirements	Uses One Module Address	Uses Two Module Addresses	
Operating Current	Standby = 250 μ A; Activated = 400 μ A	Standby = 396 μ A; Activated = 680 μ A	
Operating Voltage	15.2 to 19.95 VDC (19 VDC nominal)		
Construction	High Impact Engineering Polymer		
Mounting	North American 2½ inch (64 mm) deep one-gang boxes and 1½ inch (38 mm) deep 4 inch square boxes with one-gang covers and GSA-MP mounting plates	UIO2R/6R/6 Mother-board	
Storage and Operating Environment	Operating Temperature: 32°F to 120°F (0°C to 49°C) Storage Temperature: -4°F to 140°F (-20°C to 60°C); Humidity: 0 to 93% RH		
LED Operation	On-board Green LED - Flashes when polled; On-board Red LED - Flashes when in alarm/active Both LEDs - Glow steady when in alarm (stand-alone)		
Compatibility	Use with Signature Loop Controller		



Ordering Information

Model	P/N	Description	Ship Wt. lb (kg)
GSA-CT1	18674	Single Input Module	0.4 (0.2)
GSA-CT2	18675	Dual Input Module	0.4 (0.2)
GSA-MCT2	18681	Dual Input Plug-in (UIO) Module	0.2 (0.1)

Related Equipment			
N/A	18888	Surface Mount Box - Red, 1-gang	1.0 (0.5)
N/A	18889	Surface Mount Box - White, 1-gang	1.0 (0.5)
GSA-UIO2R	18687	Universal Input-Output Module Board w/Riser Inputs — Two Module Positions	0.3 (0.1)
GSA-UIO6R	18689	Universal Input-Output Module Board w/Riser Inputs — Six Module Positions	0.6 (0.3)
GSA-UIO6	18688	Universal Input-Output Module Board — Six Module Positions	0.6 (0.3)
MFC-A	18690	Multifunction Fire Cabinet — Red, supports Signature Module Mounting Plates	7.0 (3.2)
GSA-MP1	18684	Signature Module Mounting Plate, 1 footprint	1.5 (0.7)
GSA-MP2	18685	Signature Module Mounting Plate, 1/2 footprint	0.5 (0.2)
GSA-MP2L	18686	Signature Module Mounting Plate, 1/2 extended footprint	1.0 (0.5)

Note: Approvals/Listings maintained by and manufactured by General Electric Company.

The seller makes no warranties, express or implied, including, but not limited to, the implied warranties of merchantability and fitness for a particular purpose, except as expressly stated in the seller's sales contract or sales acknowledgment form. Every attempt is made to keep our product information up-to-date and accurate. All specific applications cannot be covered, nor can all requirements be anticipated. All specifications are subject to change without notice.



1102 Rucpich Drive
 Millennium Park
 Crown Point, IN 46307
 TEL: (219) 663-1600 FAX: (219) 663-4562
 e-mail: info@janusfiresystems.com
www.janusfiresystems.com