

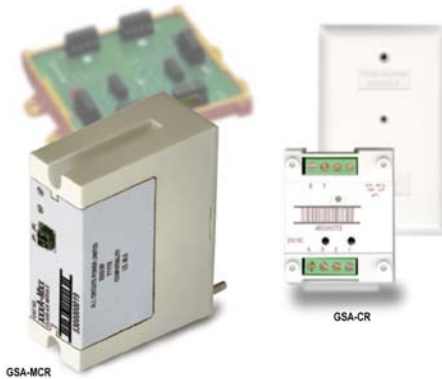

GSA-CR/MCR

CONTROL RELAY MODULES



P/N: See Chart

Standard Features

- **Provides one no/nc contact**
Form "C" dry relay contact can be used to control external appliances such as door closers, fans, dampers etc.
- **Plug-in (UIO) or standard 1-gang mount**
UIO versions allow quick installation where multiple modules are required. The 1-gang mount version is ideal for remote locations that require a single module.
- **Automatic device mapping**
Signature modules transmit information to the loop controller regarding their circuit locations with respect to other Signature devices on the wire loop.
- **Electronic addressing**
Programmable addresses are downloaded from the loop controller, a PC, or the SIGA-PRO Signature Program/Service Tool; there are no switches or dials to set.
- **Intelligent device with microprocessor**
All decisions are made at the module to allow lower communication speed with substantially improved control panel response time and less sensitivity to line noise and loop wiring properties; twisted or shielded wire is not required.
- **Ground fault detection by address**
Detects ground faults right down to the device level.

Overview

The Control Relay Module and the Polarity Reversal Relay Module are part of the Signature Series system. They are intelligent analog addressable devices available in either plug-in (UIO) versions, or standard 1-gang mount versions.

The GSA-CR/MCR Control Relay Module provides a Form "C" dry relay contact to control external appliances such as door closers, fans, dampers etc. This device does not provide supervision of the state of the relay contact. Instead, the on-board microprocessor ensures that the relay is in the proper ON/OFF state. Upon command from the loop controller, the GSA-CR/MCR relay activates the normally open or normally-closed contact.

Standard-mount version (GSA-CR) is installed to standard North American 1-gang electrical boxes, making it ideal for locations where only one module is required. Separate I/O and data loop connections are made to each module.

Plug-in UIO version (GSA-MCR) is a part of the UIO family of plug-in Signature Series modules. It functions identically to the standard mount versions, but takes advantage of the modular flexibility and easy installation that characterizes all UIO modules. Two- and six-module UIO motherboards are available. All wiring connections are made to terminal blocks on the motherboard. UIO assemblies may be mounted in Janus Fire Systems® enclosures.



Signature Series Overview

The Signature Series intelligent analog-addressable system from Janus Fire Systems is an entire family of multi-sensor detectors and mounting bases, multiple-function input and output modules, network and non-network control panels, and user-friendly maintenance and service tools. Analog information from equipment connected to Signature devices is gathered and converted into digital signals. An onboard microprocessor in each Signature device measures and analyzes the signal and decides whether or not to input an alarm. The microprocessor in each Signature device provides four additional benefits – Self-diagnostics and History Log, Automatic Device Mapping, Stand-alone Operation and Fast, Stable Communication.

Self-diagnostics and History Log – Each Signature Series device constantly runs self-checks to provide important maintenance information. The results of the self-check are automatically updated and permanently stored in its non-volatile memory. This information is accessible for review any time at the control panel, PC, or using the SIGA-PRO Signature Program/Service Tool. The information stored in device memory includes:

- Device serial number, address, and type
- Time and date of last alarm
- Most recent trouble code logged by the detector — 32 possible trouble codes may be used to diagnose faults.

Automatic Device Mapping –The Signature Data Controller (SDC) learns where each device's serial number address is installed relative to other devices on the circuit. The SDC keeps a map of all Signature Series devices connected to it. The Signature Series Data Entry Program also uses the mapping feature. With interactive menus and graphic support, the wired circuits between each device can be examined. Layout or "as-built" drawing information showing branch wiring (T-taps), device types and their address are stored on disk for printing hard copy. This takes the mystery out of the installation. The preparation of as-built drawings is fast and efficient.

Device mapping allows the Signature Data Controller to discover:

- Unexpected additional device addresses
- Missing device addresses
- Changes to the wiring in the circuit.

Most Signature modules use a personality code selected by the installer to determine their actual function. Personality codes are downloaded from the SDC during system configuration and are indicated during device mapping.

Standalone Operation – A decentralized alarm decision by the device is guaranteed. Onboard intelligence permits the device to operate in standalone (degrade) mode. If Signature loop controller CPU communications fail for more than four seconds, all devices on that circuit go into standalone mode. The circuit acts like a conventional alarm receiving circuit. Each Signature device on the circuit continues to collect and analyze information from its slave devices. When connected to a panel utilizing standalone operation, modules with their "personality" set as alarm devices (IDC) will alarm should their slave alarm-initiating device activate.

Application

The operation of Signature Series control relays is determined by their sub-type code or "Personality Code."

Personality Code 8: CONTROL RELAY (GSA-CR/MCR) - Dry Contact Output. This setting configures the module to provide one Form "C" DRY RELAY CONTACT to control Door Closers, Fans, Dampers, etc. Contact rating is 2.0 amp @ 24 VDC; 0.5 amp @ 120 VAC (or 220 VAC for non-UL applications). Personality Code 8 is assigned at the factory. No user configuration is required.



Installation

GSA-CR: modules mount to North American 2½ inch (64 mm) deep 1-gang boxes and 1½ inch (38 mm) deep 4 inch square boxes with 1-gang covers and GSA-MP mounting plates (see DS1041). The terminals are suited for #12 to #18 AWG (2.5 mm² to 0.75 mm²) wire size.

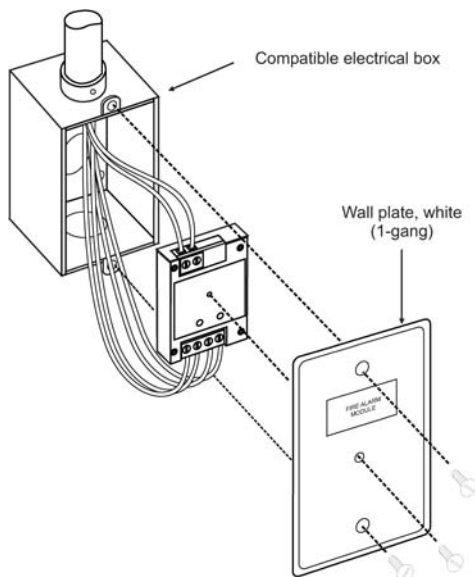

GSA-MCR: mount the UIO motherboard inside a suitable Janus Fire Systems® enclosure with screws and washers provided. Plug the module into any available position on the motherboard and secure the module to the motherboard with the captive screws. Wiring connections are made to the terminals on the motherboard (see wiring diagram). UIO motherboard terminals are suited for #12 to #18 AWG (2.5 mm² to 0.75 mm²) wire size.

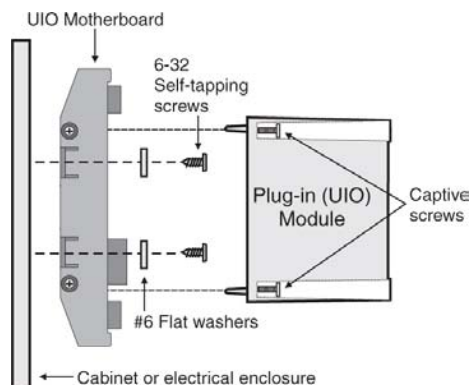

Electronic Addressing - The loop controller electronically addresses each module, saving valuable time during system commissioning. Setting complicated switches or dials is not required. Each module has its own unique serial number stored in its on-board memory. The loop controller identifies each device on the loop and assigns a “soft” address to each serial number.

Janus Fire Systems recommends that this module be installed according to latest recognized edition of national and local fire alarm codes.

Compatibility

The Signature Series modules are compatible only with Signature Loop Controllers.

Warnings & Cautions

This module will not operate without electrical power. As fires frequently cause power interruption, we suggest you discuss further safeguards with your local fire protection specialist.

Testing & Maintenance

The module’s automatic self-diagnosis identifies when it is defective and causes a trouble message. The user-friendly maintenance program shows the current state of each module and other pertinent messages. Single modules may be turned off (deactivated) temporarily, from the control panel. Availability of maintenance features is dependent on the fire alarm system used. Scheduled maintenance (Regular or Selected) for proper system operation should be planned to meet the requirements of the Authority Having Jurisdiction (AHJ). Refer to current NFPA 72 and ULC CAN/ULC 536 standards.



Typical Wiring

Modules will accept #18 AWG (0.75 mm²), #16 (1.0 mm²), #14 AWG (1.50 mm²) and #12 AWG (2.5 mm²) wire sizes.

Note: Sizes #16 AWG (1.0 mm²) and #18 AWG (0.75 mm²) are preferred for ease of installation. See Signature Loop Controller catalog sheet for detailed wiring requirement specifications.

Notes

- 1 Refer to Signature Loop Controller Installation Sheet for wiring specifications.
- 2 NFPA 72 requires that the GSA-CR/GSA-MCR be installed in the same room as the device it is controlling. This requirement may not apply in all markets. Check with your local AHJ for details.
- 3 The GSA-UIO6R and the GSA-UIO2R do not come with TB14.
- 4 The GSA-UIO6 does not come with TB8 through TB13.
- 5 Supervised and power-limited.
- 6 If the source is nonpower-limited, maintain a space of 1/4 inch from power-limited wiring or use FPL, FPLP, FPLR, or an equivalent in accordance with the National Electrical Code.
- 7) Maximum #12 AWG (2.5mm²) wire. Min. #18 (0.75mm²).

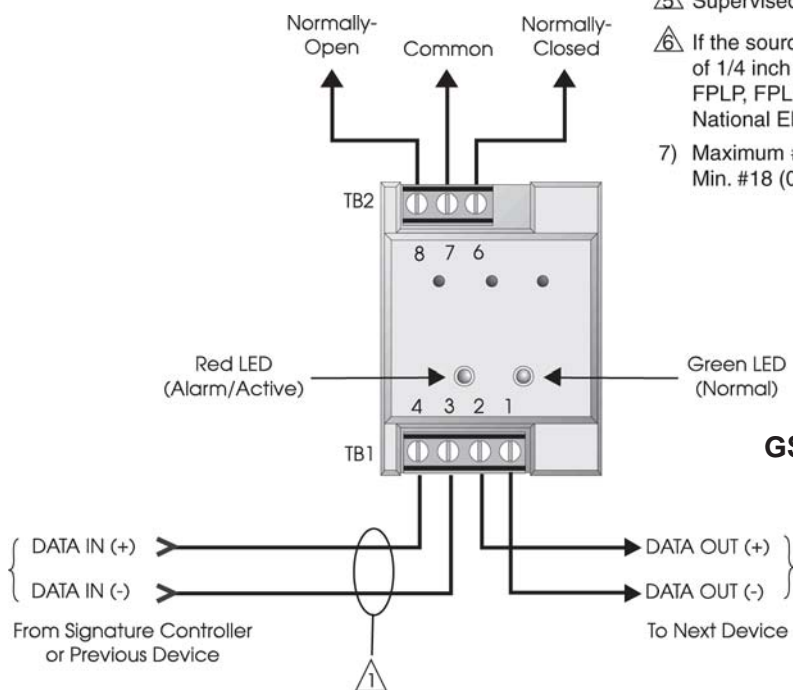

GSA-CR Control Relay

GSA-MCR Control Relay

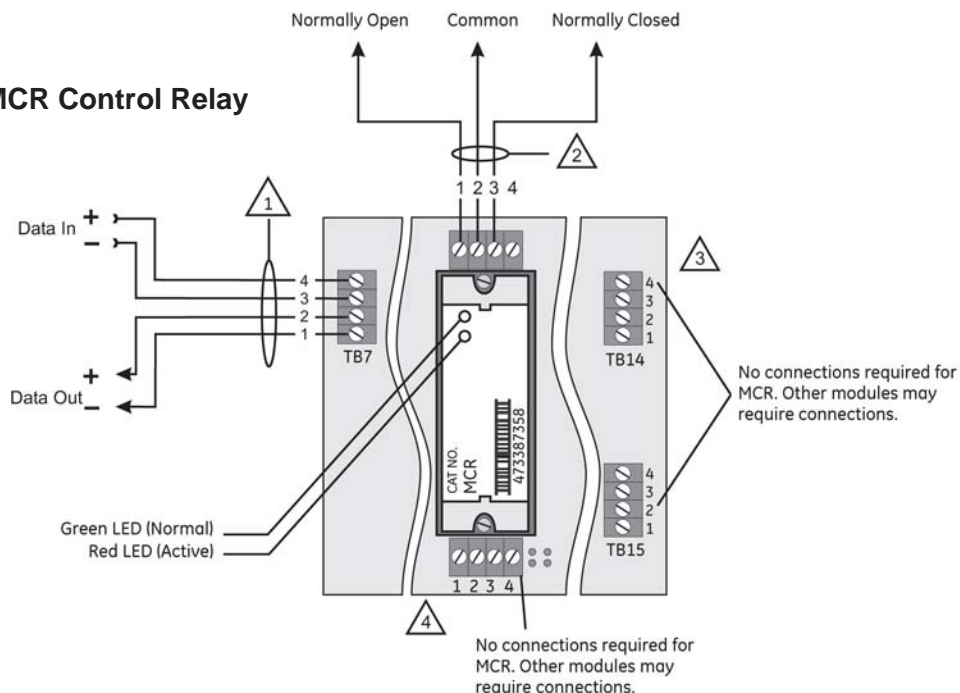



Specifications

Catalog Number	GSA-CR	GSA-MCR
Description	Control Relay	
Type Code	Personality Code 8 (Factory Set)	
Address Requirements	Uses 1 Module Address	
Operating Current	Standby = 100 μ A Activated = 100 μ A	
Operating Voltage	15.2 to 19.95 VDC (19 VDC nominal)	
Relay Type and Rating	Form "C" 24 VDC = 2 amps (pilot duty) 120 VAC = 0.5 amps 220 VAC (non-UL) = 0.5 amps	
Mounting	North American 2½ inch (64 mm) deep 1-gang boxes and 1½ inch (38 mm) deep 4 inch square boxes with 1-gang covers and GSA-MP mounting plates	Plugs into UIO2R, UIO6R or UIO6 Motherboards
Construction & Finish	High Impact Engineering Polymer	
Storage and Operating Environment	Operating Temperature: 32°F to 120°F (0°C to 49°C) Storage Temperature: -4°F to 140°F (-20°C to 60°C) Humidity: 0 to 93% RH	
LED Operation	On-board Green LED - Flashes when polled	On-board Red LED - Flashes when in alarm/active
Compatibility	Use With: Signature Loop Controller	



Ordering Information

Model	P/N	Description	Ship Wt. lb (kg)
GSA-CR	18673	Control Relay Module (Standard Mount)	0.4 (0.2)
GSA-MCR	18680	Control Relay Module (UIO Mount)	0.2 (0.1)

Related Equipment			
N/A	18888	Surface Mount Box - Red, 1-gang	1.0 (0.5)
N/A	18889	Surface Mount Box - White, 1-gang	1.0 (0.5)
GSA-UIO2R	18687	Universal Input-Output Module Board w/Riser Inputs — Two Module Positions	0.3 (0.1)
GSA-UIO6R	18689	Universal Input-Output Module Board w/Riser Inputs — Six Module Positions	0.6 (0.3)
GSA-UIO6	18688	Universal Input-Output Module Board — Six Module Positions	0.6 (0.3)

Accessories			
MFC-A	18690	Multifunction Fire Cabinet - Red, supports Signature Module Mounting Plates	7.0 (3.2)
GSA-MP1	18684	Signature Module Mounting Plate, 1 footprint	1.5 (0.7)
GSA-MP2	18685	Signature Module Mounting Plate, 1/2 footprint	0.5 (0.2)
GSA-MP2L	18686	Signature Module Mounting Plate, 1/2 extended footprint	1.0 (0.5)

Note: Approvals/Listings maintained by and manufactured by General Electric Company.

The seller makes no warranties, express or implied, including, but not limited to, the implied warranties of merchantability and fitness for a particular purpose, except as expressly stated in the seller's sales contract or sales acknowledgment form. Every attempt is made to keep our product information up-to-date and accurate. All specific applications cannot be covered, nor can all requirements be anticipated. All specifications are subject to change without notice.



1102 Rupcich Drive
 Millennium Park
 Crown Point, IN 46307
 TEL: (219) 663-1600 FAX: (219) 663-4562
 e-mail: info@janusfiresystems.com
www.janusfiresystems.com